

HYDRANT MANHOLE COVER D400/DN100

Standard: EN124-2 : 2015

EN 124 Class: D400

Maximum Load: 40 tons

Material: Grey cast iron EN-GJL-250

Surface finish: bitumen coating

Hydrant: DN 100

Height: 310 mm

Total Weight: 35 kg



Color



APPLICATION

The cast iron hydrant cover DN 100, class D400, is designed to cover and protect underground fire hydrants in areas with heavy loads, such as busy urban roads, industrial zones, logistics complexes, or heavy vehicle parking areas. Thanks to its robust construction from grey cast iron EN-GJL-250 and bitumen coating, the cover is highly resistant to mechanical damage, corrosion, and weather conditions. It ensures safe operation under loads of up to 40 tons. The height of 310 mm allows flexible installation into various types of underground chambers and provides stable and secure access to the hydrant. The cover protects the hydrant from unauthorized access and is easily identifiable in the field for quick response during a fire.



<https://vokaprodukt.cz>



+420 (774) 845 808



info@vokaprodukt.cz

MANHOLE COVER DRAWING

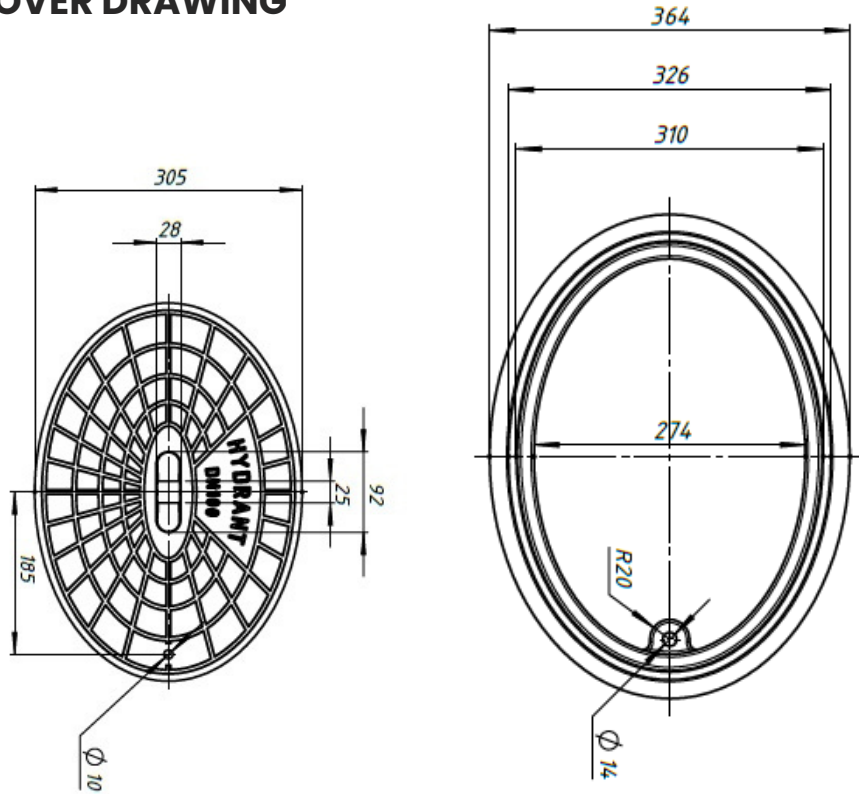

MANHOLE FRAME DRAWING

