

HYDRANT MANHOLE COVER D400/DN80

Standard: EN124-2 : 2015

EN 124 Class: D400

Maximum Load: 40 tons

Material: Grey cast iron EN-GJL-250

Surface finish: bitumen coating

Hydrant: DN 80

Height: 305 mm

Total Weight: 23,3 kg



Color



APPLICATION

Cast iron hydrant covers protect underground fire hydrants, which are essential for fire safety. They ensure quick and safe access during fires, inspections, and water system maintenance. They are used in cities, industrial areas, warehouse complexes, shopping centres, logistics parks, and residential zones with limited heavy vehicle traffic. The cover, made of grey cast iron EN-GJL-250 with a bitumen coating and weighing 30 kg, is resistant to damage, corrosion, and weather conditions. The EN 124-2:2015 standard, class D400, guarantees safe operation under loads up to 40 tons. The height of 305 mm allows for easy installation into various chambers. The cover protects the hydrant from damage and unauthorized access.



<https://vokaprodukt.cz>



+420 (774) 845 808



info@vokaprodukt.cz

MANHOLE COVER DRAWING

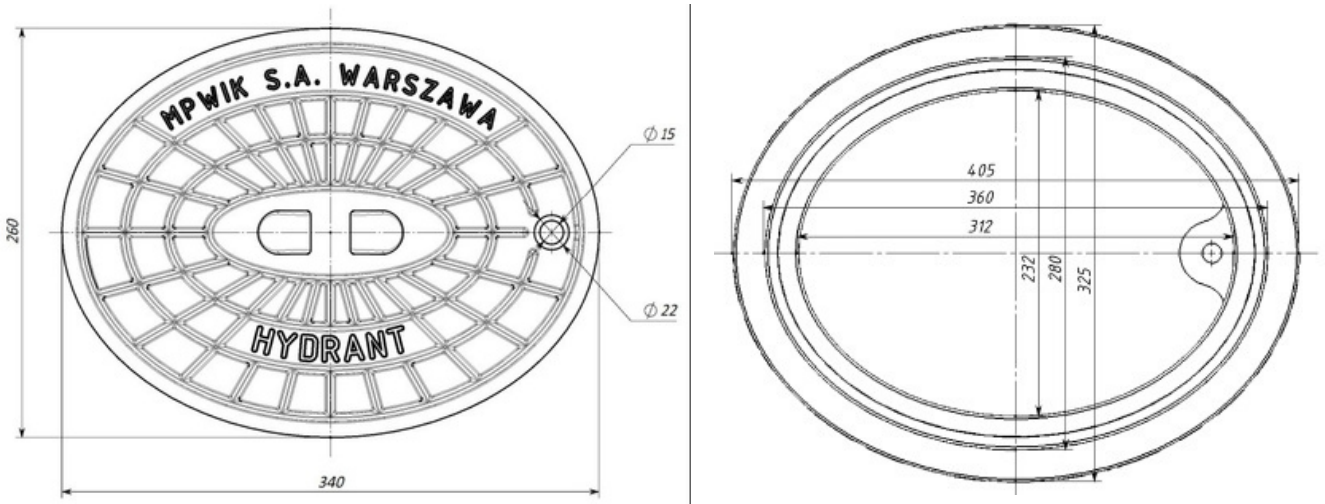

MANHOLE FRAME DRAWING

