

SEWER MANHOLE COVER D400 LOCKABLE

Standard: EN124-2 : 2015

EN 124 Class: D 400

Maximum Load: 40 tons

Material: Ductile (spheroidal) iron EN-GJS-500-7

Frame Diameter: 716 mm

Cover Diameter: 615 mm

Locking System: 2 locks

Total Weight: 80 kg

Shape: Round



Color



APPLICATION

The cast iron round manhole cover of class D400 is designed for heavy loads up to 40 tons. It is ideally suited for use on roads, streets, parking lots, industrial areas, and other locations with intensive heavy vehicle traffic. It provides a safe cover for sewer inspection chambers and ensures easy access for maintenance. The robust cast iron construction guarantees long service life, high resistance to mechanical stress, and durability under weather conditions. The locking system with two locks protects the cover from unauthorized opening and increases overall operational safety.

ON REQUEST

- Color options are available according to the offered standard colors.
- Custom design on the cover is available upon customer request.



<https://vokaprodukt.cz>



+420 (774) 845 808



info@vokaprodukt.cz

MANHOLE COVER DRAWING

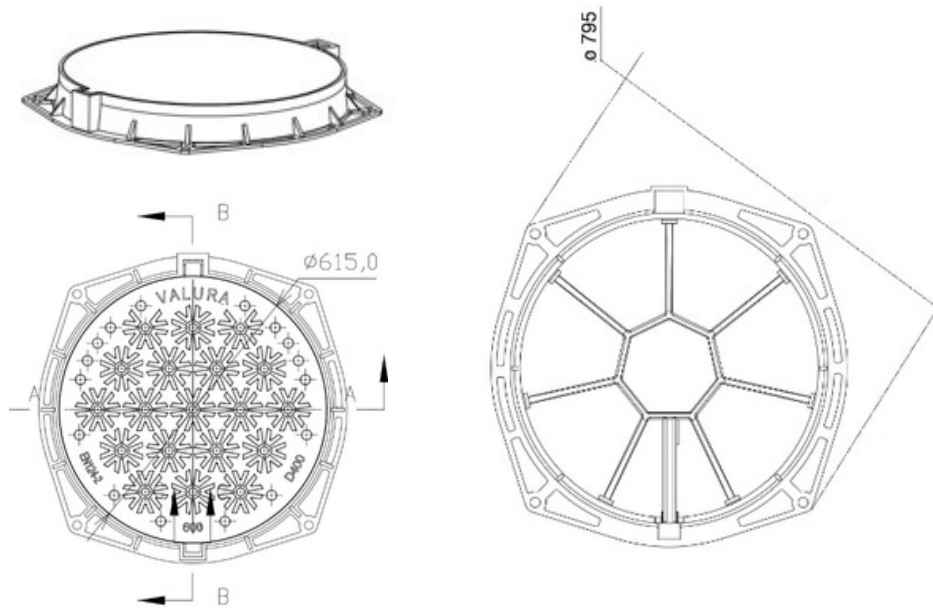

MANHOLE FRAME DRAWING

