

WATER UTILITY MANHOLE COVER D400/L150

Standard: EN124-2 : 2015

EN 124 Class: D400

Maximum Load: 40 tun

Material: Grey cast iron EN-GJL-250

Surface finish: bitumen coating

Cover diameter: 88 mm

Bottom diameter: 110 mm

Height: 150 mm

Total Weight: 6 kg



Color



APPLICATION

The cast iron water manhole cover, class D400, is designed to cover small inspection openings, primarily for access to underground shut-off valves of water connections or control heads of smaller underground hydrants (e.g., DN 25–50). Thanks to its compact size, it is suitable for urban infrastructure, roads, parking lots, or industrial areas where high load-bearing capacity is required, but only limited technical access is needed. The cast iron construction and D400 classification allow use even in locations with heavy traffic loads.



<https://vokaprodukt.cz>



+420 (774) 845 808



info@vokaprodukt.cz

MANHOLE COVER DRAWING

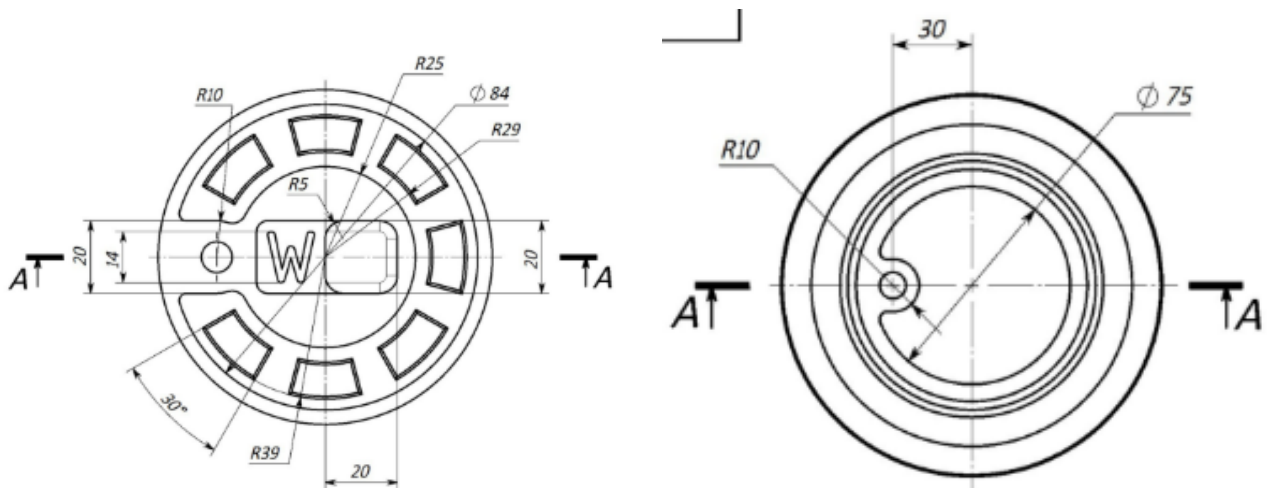

MANHOLE FRAME DRAWING

