

WATER UTILITY MANHOLE COVER D400/L270

Standard: EN124-2 : 2015

EN 124 Class: D400

Maximum Load: 40 tons

Material: Grey cast iron EN-GJL-250

Surface finish: bitumen coating

Cover diameter: 156 mm

Bottom diameter: 250 mm

Height: 270 mm

Total weight: 11 kg



Color



APPLICATION

The cast iron water manhole cover, class D400, is designed for the safe covering and access to underground parts of water supply infrastructure. It is primarily used for access to shut-off valves, control valves, and water meters located in underground chambers or shafts, technical chambers of water connections, and service entries with smaller openings in areas with heavy road traffic where high load-bearing capacity is required. Thanks to its compact construction and high durability, it is suitable for urban roads, parking lots, industrial areas, and other locations with heavy equipment traffic, even though it has a smaller access diameter. The top of the cover is usually marked with the letter "W" (short for Water) for easy identification.



<https://vokaprodukt.cz>



+420 (774) 845 808



info@vokaprodukt.cz

MANHOLE COVER DRAWING

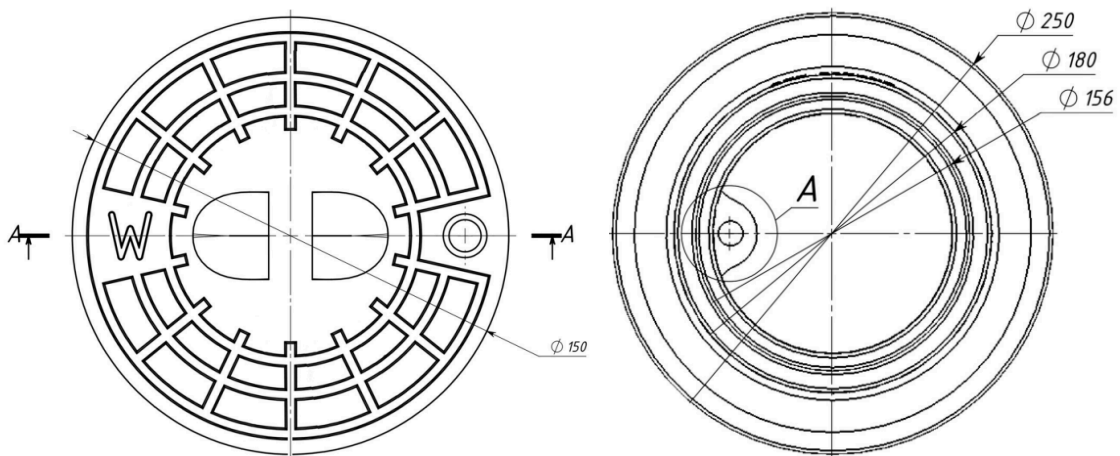

MANHOLE FRAME DRAWING

